

CHAPTER 4 : VECTORS

3.1 Introduction

Definition 3.1

A vector is a quantity that has both magnitude and direction.

A vector is often represented by an arrow or a directed line segment. The length of the arrow represents the magnitude of the vector and the arrow points in the direction of the vector. For example, force, velocity, acceleration, etc are quantity that has magnitude and direction.

Definition 3.2

A scalar is a quantity that has magnitude only.

Length, area, volume, mass, time, etc are types of scalar that has magnitude only.

3.2 Vector Representation

Suppose a particle moves along a line segment from point P to point Q . The corresponding displacement vector, shown in figure below, has initial point P (the tail) and the point Q is referred as its head and we indicate this by writing \overrightarrow{PQ} . Notice that the vector \overrightarrow{QP} has the same length but it is in the opposite direction.

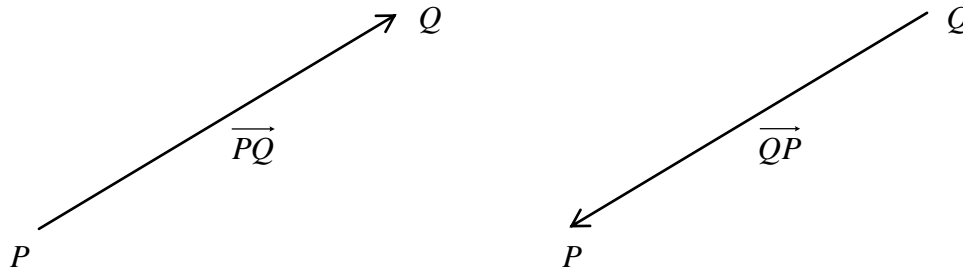

A vector could be written as \underline{a} , \underline{b} , \underline{u} , \underline{v} and \underline{w} . The magnitude of the vector, \underline{v} is denoted by $|\underline{v}|$. Note that $-\underline{v}$ would represent a vector of the same magnitude but with opposite direction.

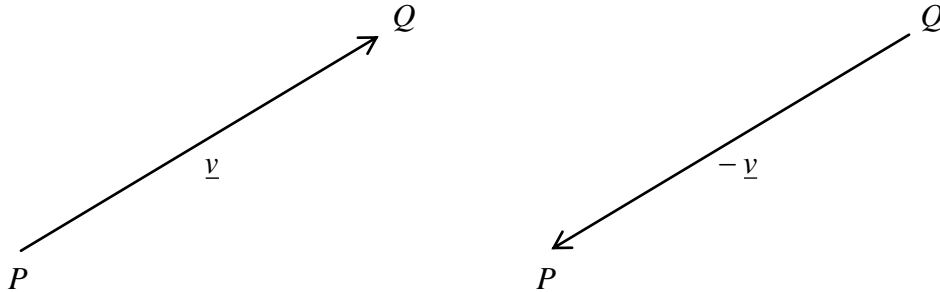

3.3 Two Equal Vectors

Definition 3.3

Two vectors \underline{u} and \underline{v} are said to be equal if and only if they have the same magnitude and the same direction

Example 1 :

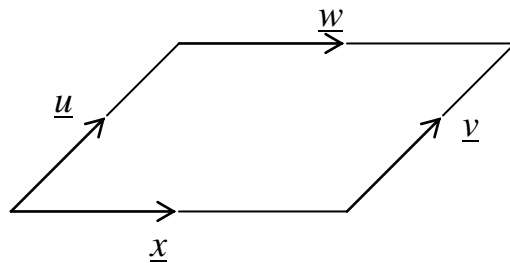

$$\underline{u} = \underline{v} \text{ and } \underline{w} = \underline{x}$$

3.4 Addition of Vectors

Definition 3.4

If \underline{u} and \underline{v} are vectors, then the addition of \underline{u} and \underline{v} can be written as $\underline{u} + \underline{v}$.

i) The Triangle Law

If \underline{u} and \underline{v} are vectors, we connect the initial point of \underline{v} with the terminal point of \underline{u} , then the sum $\underline{u} + \underline{v}$ is the vector from the initial point of \underline{u} to the terminal point of \underline{v} .

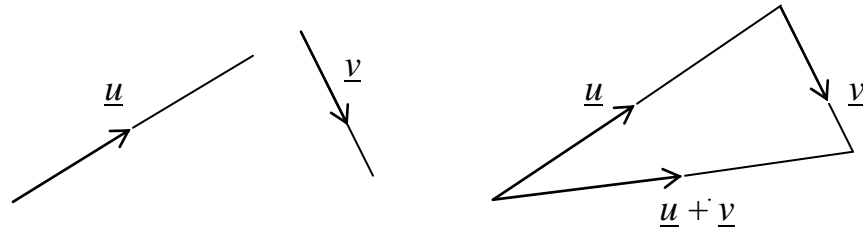
Example 2 :

ii) The Parallelogram Law

In figure below, we start with the same vectors \underline{u} and \underline{v} as in figure above and we draw another copy of \underline{v} with the same initial point as \underline{u} . Completing the parallelogram, we could see that $\underline{u} + \underline{v} = \underline{v} + \underline{u}$. This also give another way to construct the sum : if we place \underline{u} and \underline{v} so they start at the same point, then $\underline{u} + \underline{v}$ lies along the diagonal of the parallelogram with \underline{u} and \underline{v} as sides.

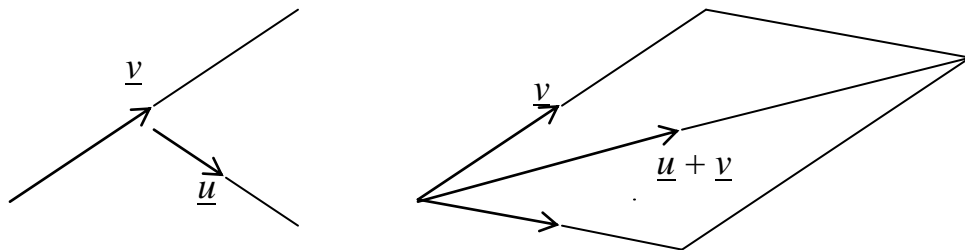
Example 3 :iii) The Sum of a Number of Vectors \underline{u}

The sum of all vectors is given by the single vector joining the start of the first to the end of last.

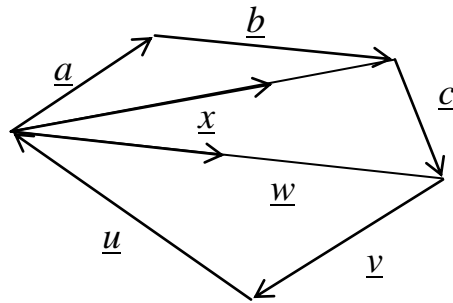
Example 4:

1. $\underline{a} + \underline{b} = \underline{x}$
2. $\underline{a} + \underline{b} + \underline{c} = \underline{w}$

Note: Addition of vector is satisfied $\underline{u} + \underline{v} = \underline{v} + \underline{u}$ (commutative law)

3.5 Subtraction of Vectors**Definition 3.5**

If \underline{u} and \underline{v} are vectors, then $\underline{u} - \underline{v}$ can be written as $\underline{u} + (-\underline{v})$

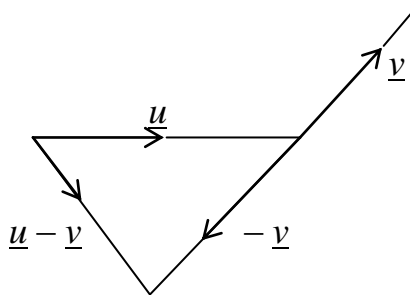
Example 5:

Note: Subtraction of vectors is not satisfied the commutative law, but their magnitudes are still the same even though the direction is opposite.

3.6 Scalar Multiplication of Vectors

Definition 3.6

If \underline{v} is a vector and α is a scalar, then the scalar multiplication $\alpha\underline{v}$ is a vector whose length is $|\alpha|$ times the length of \underline{v} and whose direction is the same as \underline{v} if $\alpha > 0$ and is opposite to \underline{v} if $\alpha < 0$.

Example 6 :

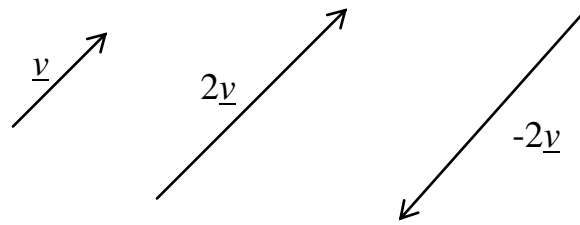

3.7 Parallel Vectors

Definition 3.7

Two vectors \underline{u} and \underline{v} are said to be parallel if they are in the same direction or opposite direction and \underline{v} is equivalent to $\alpha\underline{u}$.

Example 7:

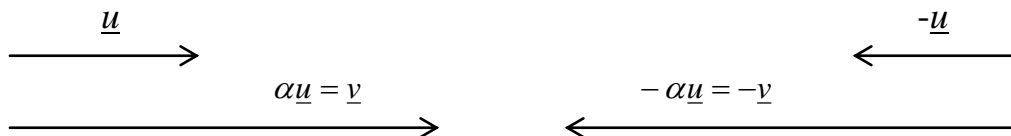

3.8 Components of Vectors in Terms of Unit Vectors

If we place the initial point of a vector \underline{r} at the origin of a rectangular coordinate system, then the terminal point of \underline{r} has coordinate of the form $\langle x, y, z \rangle$. These coordinates are called the components of \underline{r} and we write

$$\underline{r} = x\underline{i} + y\underline{j} + z\underline{k}$$

Where, \underline{i} , \underline{j} and \underline{k} are unit vectors in the x , y and z -axes, respectively.

Unit vectors $\underline{i}, \underline{j}, \underline{k}$.

$\underline{i} = \langle 1, 0, 0 \rangle$ to be a unit vector in the ox direction (x -axis)

$\underline{j} = \langle 0, 1, 0 \rangle$ to be a unit vector in the oy direction (y -axis)

$\underline{k} = \langle 0, 0, 1 \rangle$ to be a unit vector in the oz direction (z -axis)

3.8.1 Vectors in Two Dimension (R^2)

Two unit vectors along ox and oy direction are denoted by the symbol \underline{i} and \underline{j} respectively.

Example 8 : $\underline{u} = 3\underline{i} + 4\underline{j}$

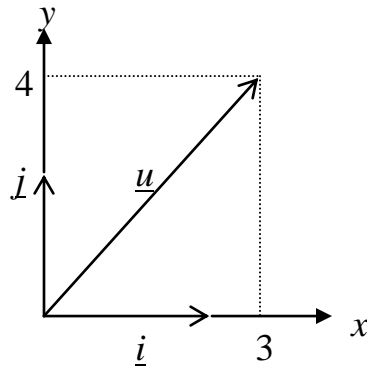

3.8.2 Vectors in Three Dimension (R^3)

Three unit vectors along ox , oy and oz direction are denoted by the symbol \underline{i} , \underline{j} and \underline{k} respectively.

Example 9 : $\underline{u} = \underline{i} + 3\underline{j} + 5\underline{k}$

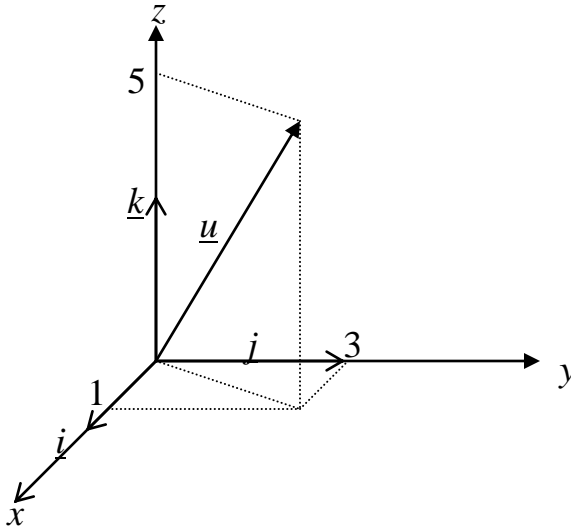

3.9 Position Vectors

Definition 3.8

If r represents the vector from the origin to the point $P(a, b, c)$ in R^3 , then the position vector of P can be defined by

$$r = \overrightarrow{OP} = (a, b, c) - (0, 0, 0) = \langle a, b, c \rangle$$

Example 10

Two forces D and E are acts from the origin point O . If $D = 46\text{N}$, $\theta_D = 0^\circ$ and $E = 17\text{N}$, $\theta_E = 90^\circ$. Find the resultant force.

Solution

Position vector

$$\overrightarrow{OD} = 46\underline{i} \text{ and } \overrightarrow{OE} = 17\underline{j}$$

Hence, the additional force is $\overrightarrow{OD} + \overrightarrow{OE} = 46\underline{i} + 17\underline{j}$.

3.10 Components of Vectors

Definition 3.9

If P and Q are two points in R^3 where $P(a, b, c)$ and $Q(x, y, z)$, then the components vector P and Q can be defined by

$$\overrightarrow{PQ} = \overrightarrow{OQ} - \overrightarrow{OP} = (x, y, z) - (a, b, c) = \langle x - a, y - b, z - c \rangle$$

Example 11

Given $P(5, 2, 1)$ and $Q(6, 1, 7)$ are two points in R^3 . Find the components vector of \overrightarrow{PQ} .

Solution

$$\overrightarrow{PQ} = \overrightarrow{OQ} - \overrightarrow{OP} = \langle 6, 1, 7 \rangle - \langle 5, 2, 1 \rangle = \langle 1, -1, 6 \rangle.$$

3.11 Magnitude (Length) of Vectors

Definition 3.10

If \underline{u} is a vector with the components $\langle a, b, c \rangle$, then the magnitude of vector \underline{u} can be written as

$$|\underline{u}| = \sqrt{a^2 + b^2 + c^2}$$

Example 12

Find the magnitude of the following vectors:

- i) $\underline{u} = \langle 5, 2 \rangle = 5\mathbf{i} + 2\mathbf{j}$
- ii) $\underline{u} = \langle 5, 2, 1 \rangle = 5\mathbf{i} + 2\mathbf{j} + \mathbf{k}$

Solutions

- i) $|\underline{u}| = \sqrt{5^2 + 2^2} = \sqrt{29}$
- ii) $|\underline{u}| = \sqrt{5^2 + 2^2 + 1^2} = \sqrt{30}$

Definition 3.11

If P and Q are two points with coordinate (a, b, c) and (x, y, z) , respectively, then the length from P to Q can be written as

$$|\overrightarrow{PQ}| = \sqrt{(x-a)^2 + (y-b)^2 + (z-c)^2}$$

Example 13

If $P(5, 2, 1)$ and $Q(6, 1, 7)$ in R^3 . Find the length from P to Q .

Solution

$$|\overrightarrow{PQ}| = \sqrt{(6-5)^2 + (1-2)^2 + (7-1)^2} = \sqrt{1^2 + (-1)^2 + 6^2} = \sqrt{38}$$

3.12 Unit Vectors**Definition 3.12**

If \underline{u} is a vector, then the unit vector $\hat{\underline{u}}$ is defined by $\hat{\underline{u}} = \frac{\underline{u}}{|\underline{u}|}$, where

$$|\hat{\underline{u}}| = 1.$$

A unit vector is a vector whose length is 1. Normally, the symbol ‘ $\hat{\underline{u}}$ ’ is used to represent the unit vector. In general, if $\underline{u} \neq 0$, then the unit vector that has the same direction as \underline{u} is,

$$\hat{\underline{u}} = \frac{1}{|\underline{u}|} \underline{u} = \frac{\underline{u}}{|\underline{u}|}$$

In order to verify this, let $c = \frac{1}{|\underline{u}|}$. Then $\hat{\underline{u}} = c\underline{u}$ and c is a positive

scalar, so $\hat{\underline{u}}$ has the same direction as \underline{u} . Also

$$|\hat{\underline{u}}| = |c\underline{u}| = c \|\underline{u}\| = \frac{1}{|\underline{u}|} \|\underline{u}\| = 1$$

Example 14

Find the unit vector in the direction of the vector $\underline{u} = 3\underline{i} + 4\underline{j} + 2\underline{k}$.

Solutions

$$|\underline{u}| = \sqrt{3^2 + 4^2 + 2^2} = \sqrt{29}$$

$$\hat{\underline{u}} = \frac{3}{\sqrt{29}}\underline{i} + \frac{4}{\sqrt{29}}\underline{j} + \frac{2}{\sqrt{29}}\underline{k}$$

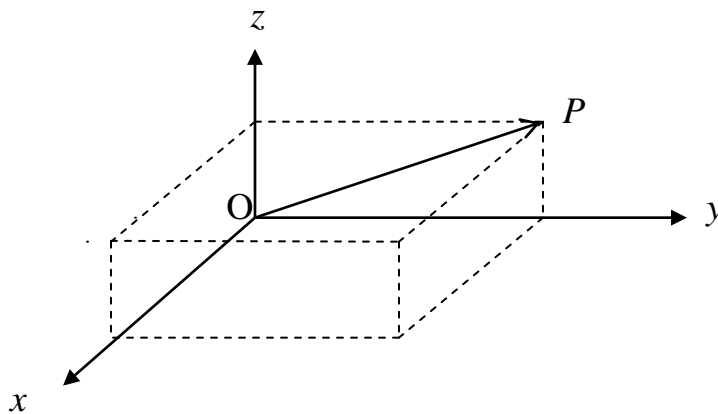
3.13 Direction Angles and Direction Cosines

The direction angles of a vector $\overrightarrow{OP} = x\underline{i} + y\underline{j} + z\underline{k}$ are the angles α , β and γ that \overrightarrow{OP} makes with the positive x -, y - and z -axes. The cosines of these direction angles, $\cos \alpha$, $\cos \beta$ and $\cos \gamma$ are called the direction cosines of the vector \overrightarrow{OP} and defined by

$$\cos \alpha = \frac{x}{|\overrightarrow{OP}|}, \quad \cos \beta = \frac{y}{|\overrightarrow{OP}|}, \quad \cos \gamma = \frac{z}{|\overrightarrow{OP}|}. \quad [0 \leq \alpha, \beta, \gamma \leq 180^\circ]$$

Example 15

Find the direction angles of the vector $\underline{u} = 6\underline{i} - 5\underline{j} + 8\underline{k}$

Solution

$$|\underline{u}| = \sqrt{36 + 25 + 64} = \sqrt{125} = 5\sqrt{5}.$$

$$\cos \alpha = \frac{6}{5\sqrt{5}}, \quad \cos \beta = \frac{-5}{5\sqrt{5}}, \quad \cos \gamma = \frac{8}{5\sqrt{5}}$$

3.14 Operations of Vectors by Components

Definition 3.13

If $\underline{u} = \langle u_1, u_2, u_3 \rangle$, $\underline{v} = \langle v_1, v_2, v_3 \rangle$ and k is a scalar, then

- i) $\underline{u} + \underline{v} = \langle u_1 + v_1, u_2 + v_2, u_3 + v_3 \rangle$
- ii) $\underline{u} - \underline{v} = \langle u_1 - v_1, u_2 - v_2, u_3 - v_3 \rangle$
- iii) $k\underline{u} = \langle ku_1, ku_2, ku_3 \rangle$

Example 16

Given $\underline{u} = \langle 2, -1, 1 \rangle$ and $\underline{v} = \langle 1, 3, -2 \rangle$. Find

- i) $\underline{u} + \underline{v}$
- ii) $\underline{u} - \underline{v}$
- iii) $\underline{v} - \underline{u}$
- iv) $3\underline{u}$
- v) $4\underline{v}$

Solutions

- i) $\underline{u} + \underline{v} = \langle 3, 2, -1 \rangle$
- ii) $\underline{u} - \underline{v} = \langle 1, -4, 3 \rangle$
- iii) $\underline{v} - \underline{u} = \langle -1, 4, -3 \rangle$
- iv) $3\underline{u} = \langle 6, -3, 3 \rangle$
- v) $4\underline{v} = \langle 4, 12, -8 \rangle$

Properties of A Vectors

If \underline{a} , \underline{b} , and \underline{c} are vectors, k and t are scalar, then

- i) $\underline{a} + \underline{b} = \underline{b} + \underline{a}$
- ii) $\underline{a} + (\underline{b} + \underline{c}) = (\underline{a} + \underline{b}) + \underline{c}$
- iii) $\underline{a} + \underline{0} = \underline{0} + \underline{a} = \underline{a}$
- iv) $\underline{a} + (-\underline{a}) = (-\underline{a}) + \underline{a} = \underline{0}$
- v) $k(\underline{a} + \underline{b}) = k\underline{a} + k\underline{b}$
- vi) $(k + t)\underline{a} = k\underline{a} + t\underline{a}$
- vii) $k(t\underline{b}) = (kt)\underline{b}$
- viii) $0\underline{c} = \underline{0}$
- ix) $1\underline{a} = \underline{a}$
- x) $-1\underline{b} = -\underline{b}$

3.15 Product of Two Vectors

Definition 3.14 (The Dot/Scalar Product)

If $\underline{u} = u_1\underline{i} + u_2\underline{j} + u_3\underline{k}$ and $\underline{v} = v_1\underline{i} + v_2\underline{j} + v_3\underline{k}$ are vectors in R^3 , then the dot product of \underline{u} and \underline{v} can be written as

$$\underline{u} \cdot \underline{v} = u_1 v_1 + u_2 v_2 + u_3 v_3$$

Theorem 1

If θ is the angle between the vectors \underline{u} and \underline{v} , then

$$\cos \theta = \frac{\underline{u} \cdot \underline{v}}{|\underline{u}| |\underline{v}|} ; 0 \leq \theta \leq \pi$$

Example 17

Find the angle between the vectors $\underline{u} = 4\underline{i} - 5\underline{j} - \underline{k}$ and $\underline{v} = \underline{i} + 2\underline{j} + 3\underline{k}$.

Solution

$$\underline{u} \cdot \underline{v} = (4 \times 1) + (-5 \times 2) + (-1 \times 3) = -9$$

$$|\underline{u}| = \sqrt{4^2 + (-5)^2 + (-1)^2} = \sqrt{42}$$

$$|\underline{v}| = \sqrt{1^2 + 2^2 + 3^2} = \sqrt{14}$$

From the theorem 1,

$$\cos \theta = \frac{\underline{u} \cdot \underline{v}}{|\underline{u}| |\underline{v}|} = \frac{-9}{\sqrt{42}\sqrt{14}} = \frac{-9}{2\sqrt{147}}$$

Therefore,

$$\theta = \cos^{-1}\left(\frac{-9}{2\sqrt{147}}\right) = 111.79^\circ.$$

Properties of the Dot Product

i) $\underline{u} \cdot \underline{v} = \underline{v} \cdot \underline{u}$

ii) $\underline{u} \cdot (\underline{v} + \underline{w}) = \underline{u} \cdot \underline{v} + \underline{u} \cdot \underline{w}$

iii) $(\underline{u} + \underline{v}) \cdot (\underline{w} + \underline{z}) = \underline{u} \cdot \underline{w} + \underline{v} \cdot \underline{w} + \underline{u} \cdot \underline{z} + \underline{v} \cdot \underline{z}$

iv) If k is a scalar, then $k(\underline{u} \cdot \underline{v}) = (k\underline{u}) \cdot \underline{v} = \underline{u} \cdot (k\underline{v})$

vi) $\underline{i} \cdot \underline{i} = \underline{j} \cdot \underline{j} = \underline{k} \cdot \underline{k} = 1$

vii) If \underline{u} and \underline{v} are orthogonal, then $\underline{u} \cdot \underline{v} = 0$

vii) $\underline{i} \cdot \underline{j} = \underline{j} \cdot \underline{k} = \underline{k} \cdot \underline{i} = 0$

viii) $\underline{u} \cdot \underline{u} = |\underline{u}|^2$

Definition 3.15 (The Cross Product)

If $\underline{u} = \langle u_1, u_2, u_3 \rangle$ and $\underline{v} = \langle v_1, v_2, v_3 \rangle$ are vectors, then the cross product of \underline{u} and \underline{v} is the vector

$$\underline{u} \times \underline{v} = \begin{vmatrix} \underline{i} & \underline{j} & \underline{k} \\ u_1 & u_2 & u_3 \\ v_1 & v_2 & v_3 \end{vmatrix} = (u_2v_3 - u_3v_2)\underline{i} - (u_1v_3 - u_3v_1)\underline{j} + (u_1v_2 - u_2v_1)\underline{k}$$

Example 18

If $\underline{u} = 3\underline{i} + 6\underline{j} + \underline{k}$ and $\underline{v} = 4\underline{i} + 5\underline{j} - 2\underline{k}$. Find

i) $\underline{u} \times \underline{v}$

ii) $\underline{v} \times \underline{u}$

Solutions

i) $\underline{u} \times \underline{v} = -17\underline{i} + 10\underline{j} - 9\underline{k}$

ii) $\underline{v} \times \underline{u} = 17\underline{i} - 10\underline{j} + 9\underline{k}$

Theorem 2

If $\underline{u} = \langle u_1, u_2, u_3 \rangle$ and $\underline{v} = \langle v_1, v_2, v_3 \rangle$ are vectors in R^3 , then

$$\underline{u} \times \underline{v} = |\underline{u}||\underline{v}| \sin \theta \hat{n}$$

where θ is the angle between the vectors \underline{u} and \underline{v} and \hat{n} is a normal unit vector that perpendicular to both \underline{u} and \underline{v} .

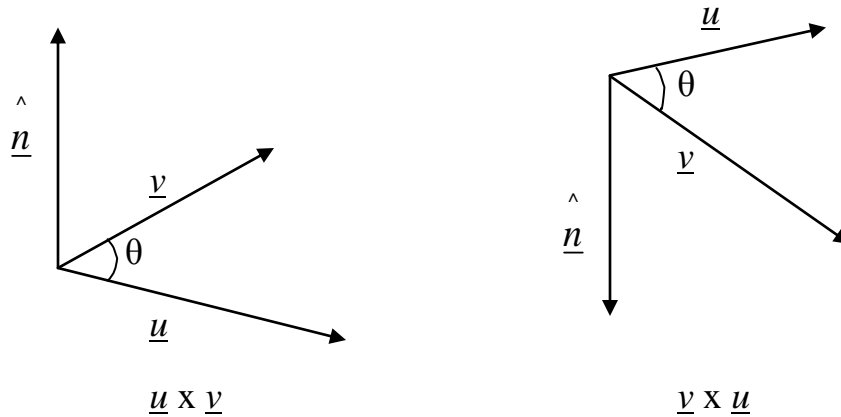

Note that:

$$\underline{u} \times \underline{v} = |\underline{u}||\underline{v}| \sin \theta \hat{n}$$

$$|\underline{u} \times \underline{v}| = ||\underline{u}||\underline{v}| \sin \theta \hat{n} |$$

$$|\underline{u} \times \underline{v}| = |\underline{u}||\underline{v}| \sin \theta$$

= Area of the parallelogram determined by \underline{u} and \underline{v} .

Example 19

Find the angle between the vectors $\underline{u} = 4\mathbf{i} + 5\mathbf{j} - 3\mathbf{k}$ and $\underline{v} = 2\mathbf{i} + \mathbf{j}$.

Solution

$$\underline{u} \times \underline{v} = \begin{vmatrix} \underline{i} & \underline{j} & \underline{k} \\ 4 & 5 & -3 \\ 2 & 1 & 0 \end{vmatrix} = 3\underline{i} - 6\underline{j} - 6\underline{k}$$

$$|\underline{u} \times \underline{v}| = \sqrt{3^2 + (-6)^2 + (-6)^2} = 9$$

$$|\underline{u}| = 5\sqrt{2} \text{ and } |\underline{v}| = \sqrt{5}$$

$$\sin \theta = \frac{|\underline{u} \times \underline{v}|}{|\underline{u}||\underline{v}|} = \frac{9}{5\sqrt{2}\sqrt{5}} = 0.5692$$

$$\theta = \sin^{-1}(0.5692) = 34.70^\circ$$

Properties of the Cross Product

If \underline{u} , \underline{v} , \underline{w} are vectors and k is a scalar, then

- i) $\underline{u} \times \underline{v} = -\underline{v} \times \underline{u}$
- ii) $\underline{u} \times (\underline{v} + \underline{w}) = \underline{u} \times \underline{v} + \underline{u} \times \underline{w}$
- iii) $\underline{u} \times k\underline{v} = (k\underline{u}) \times \underline{v} = k(\underline{u} \times \underline{v})$
- iv) $\underline{u} \times \underline{0} = \underline{0} \times \underline{u} = \underline{0}$
- v) $\underline{u} \times \underline{v} = \underline{0}$ if and only if $\underline{u} // \underline{v}$
- vi) $|\underline{u} \times \underline{v}| = |\underline{u}||\underline{v}| \sin \theta$
- viii) $\underline{i} \times \underline{i} = \underline{j} \times \underline{j} = \underline{k} \times \underline{k} = \underline{0}$
- ix) $\underline{i} \times \underline{j} = \underline{k}$; $\underline{j} \times \underline{k} = \underline{i}$; $\underline{k} \times \underline{i} = \underline{j}$
- x) $\underline{j} \times \underline{i} = -\underline{k}$; $\underline{k} \times \underline{j} = -\underline{i}$; $\underline{i} \times \underline{k} = -\underline{j}$

3.16 Applications of the Dot Product and Cross Product

i) Projections

Figure below shows representations \overrightarrow{PQ} and \overrightarrow{PR} of two vectors a and b with the same initial point P . If S is the foot of the perpendicular from R to the lines containing \overrightarrow{PQ} , then the vector with representation \overrightarrow{PS} is called the vector projection of b onto a and is denoted by $\text{proj}_a b$.

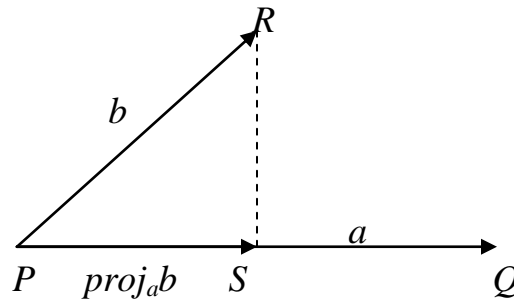

The scalar projection of b onto a (also called the component of b along a) is defined to be magnitude of the vector projection, which is the number $|b| \cos \theta$, where θ is the angle between a and b . This is denoted by $\text{comp}_a b$. The equation

$$a \cdot b = |a| |b| \cos \theta$$

shows that the dot product of a and b can be interpreted as the length of a times the scalar projection of b onto a . Since

$$|b| \cos \theta = \frac{a \cdot b}{|a|} = \frac{a}{|a|} \cdot b$$

the component of b along a can be computed by taking the dot product of b with the unit vector in the direction of a .

Theorem 3

Scalar projection of b onto a : $comp_a b = \frac{a \cdot b}{|a|}$

Vector projection of b onto a : $proj_a b = \left(\frac{a \cdot b}{|a|} \right) \frac{a}{|a|} = \frac{a \cdot b}{|a|^2} a$

Example 20

Given $\underline{b} = \underline{i} + \underline{j} + 2\underline{k}$ and $\underline{a} = -2\underline{i} + 3\underline{j} + \underline{k}$. Find the scalar projection and vector projection of \underline{b} onto \underline{a} .

Solution

Since $|a| = \sqrt{(-2)^2 + (3^2) + 1^2} = \sqrt{14}$, the scalar projection of b onto a is

$$comp_a b = \frac{a \cdot b}{|a|} = \frac{(-2)(1) + 3(1) + 1(2)}{\sqrt{14}} = \frac{3}{\sqrt{14}}$$

The vector projection is this scalar projection times the unit vector in the direction of a is

$$proj_a b = \left(\frac{3}{\sqrt{14}} \right) \frac{a}{|a|} = \left\langle -\frac{3}{7}, \frac{9}{14}, \frac{3}{14} \right\rangle$$

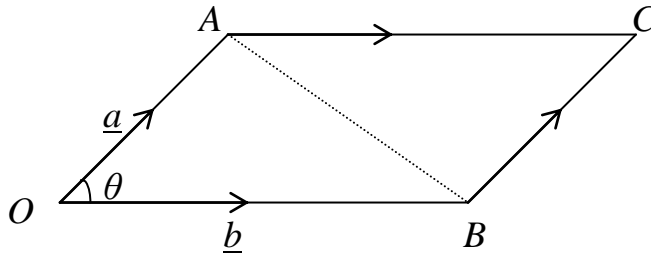
ii) The Area of Triangle and Parallelogram

$$\text{Area of triangle } OBC = \frac{1}{2} |\underline{a}| |\underline{b}| \sin \theta = \frac{1}{2} |\underline{a} \times \underline{b}|$$

$$\text{Area of parallelogram } OBCA = |\underline{a}| |\underline{b}| \sin \theta = |\underline{a} \times \underline{b}|$$

Find the area of triangle and parallelogram with $A(1,-1, 0)$, $B(2, 1, -1)$ and $C(-1, 1, 2)$.

Solution

$$\overrightarrow{AB} = \overrightarrow{OB} - \overrightarrow{OA} = \langle 2, 1, -1 \rangle - \langle 1, -1, 0 \rangle = \langle 1, 2, -1 \rangle$$

$$\overrightarrow{AC} = \overrightarrow{OC} - \overrightarrow{OA} = \langle -1, 1, 2 \rangle - \langle 1, -1, 0 \rangle = \langle -2, 2, 2 \rangle$$

$$\overrightarrow{AB} \times \overrightarrow{AC} = \begin{vmatrix} \underline{i} & \underline{j} & \underline{k} \\ 1 & 2 & -1 \\ -2 & 2 & 2 \end{vmatrix} = 6\underline{i} + 6\underline{k} = \langle 6, 0, 6 \rangle$$

$$\begin{aligned} \text{Area of triangle } ABC &= \frac{1}{2} |\overrightarrow{AB} \times \overrightarrow{AC}| \\ &= \frac{1}{2} |6\underline{i} + 6\underline{j}| \\ &= \frac{1}{2} \sqrt{6^2 + 6^2} \\ &= \frac{1}{2} \sqrt{72} \\ &= 3\sqrt{2} \end{aligned}$$

Area of parallelogram with adjacent sides \overrightarrow{AB} and \overrightarrow{AC} is the length of cross product $|\overrightarrow{AB} \times \overrightarrow{AC}| = \sqrt{72}$.

iii) The Volume of Parallelepiped and Tetrahedron

Parallelepiped determined by three vectors \vec{a} , \vec{b} and \vec{c} .

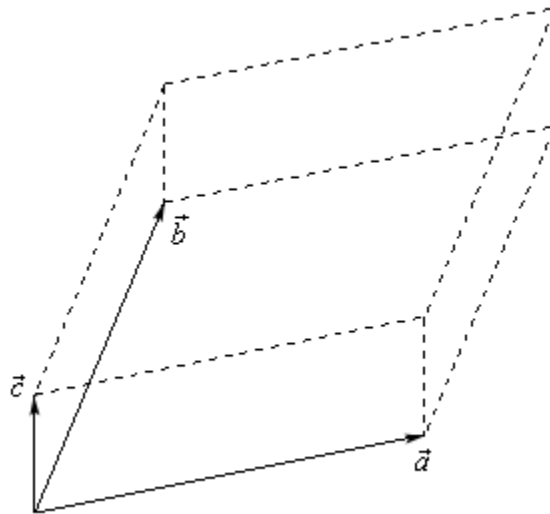

The volume of the parallelepiped determined by the vectors \underline{a} , \underline{b} and \underline{c} is the magnitude of their scalar triple product

$$V = | \underline{a} \cdot (\underline{b} \times \underline{c}) |$$

Notice that:

- i) $\underline{a} \cdot (\underline{b} \times \underline{c}) = (\underline{a} \times \underline{b}) \cdot \underline{c}$
 $\underline{a} \cdot (\underline{b} \times \underline{c})$ if $\vec{a} = \langle a_1, a_2, a_3 \rangle$, $\vec{b} = \langle b_1, b_2, b_3 \rangle$ and $\vec{c} = \langle c_1, c_2, c_3 \rangle$ so

$$\underline{a} \cdot (\underline{b} \times \underline{c}) = \begin{vmatrix} a_1 & a_2 & a_3 \\ b_1 & b_2 & b_3 \\ c_1 & c_2 & c_3 \end{vmatrix}$$

- ii) If $\underline{a} \cdot (\underline{b} \times \underline{c}) = 0$, then the all vectors on a same plane.

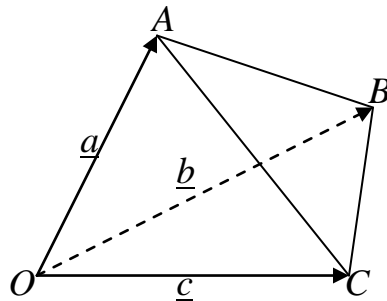

The volume of the tetrahedron by the vectors \underline{a} , \underline{b} and \underline{c} is $\frac{1}{6}$ of the volume of parallelepiped, that is $V = \frac{1}{6} | \underline{a} \cdot (\underline{b} \times \underline{c}) |$.

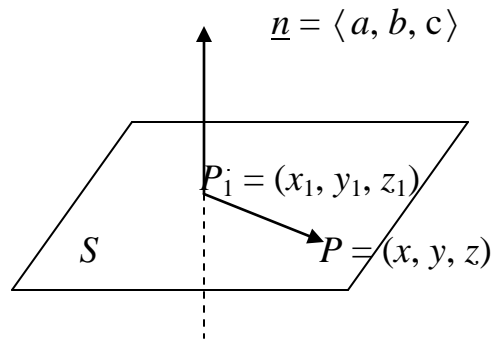
iv) **Equations of Planes**

Let $P(x, y, z)$ a point on the plane S and \underline{n} is normal vector to the plane S . If $P_1(x_1, y_1, z_1)$ is an arbitrary point in the plane S , then

$$\overrightarrow{P_1P} \cdot \underline{n} = 0$$

$$\langle x - x_1, y - y_1, z - z_1 \rangle \cdot \langle a, b, c \rangle = 0$$

$$a(x - x_1) + b(y - y_1) + c(z - z_1) = 0$$

So that, the equation of the plane is given by

$$ax + by + cz + k = 0; \text{ where } k = -ax_1 - by_1 - cz_1$$

Example 22

Find an equation of the plane through the point $P(3, -1, 7)$ with normal vector $\underline{n} = \langle 4, 2, 5 \rangle$.

Solution

Let $Q(x, y, z)$ be any point on plane S and through the point $P(3, -1, 7)$, then

$$\overrightarrow{PQ} \cdot \underline{n} = 0$$

$$\langle x - 3, y + 1, z - 7 \rangle \cdot \langle 4, 2, 5 \rangle = 0$$

$$4(x - 3) + 2(y + 1) + 5(z - 7) = 0$$

So that, the equation of the plane through P with normal vector \underline{n} is $4x + 2y + 5z - 45 = 0$.

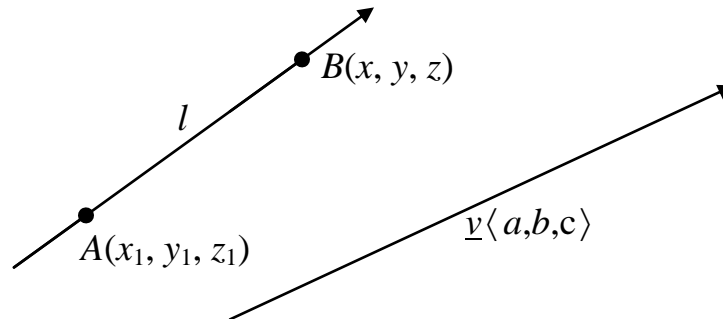
v) **Parametric Equations of A Line in R^3** 

A line l in three-dimensional space is determined when we know a point $A(x_1, y_1, z_1)$ on l and the direction of l . The direction of line is conveniently described by a vector, so we let \underline{y} be a vector parallel to l . If $B(x, y, z)$ be an arbitrary point on l , then

$$\overrightarrow{AB} = t \cdot \underline{y}; \quad t \text{ is a scalar}$$

become

$$\langle x - x_1, y - y_1, z - z_1 \rangle = t \cdot \langle a, b, c \rangle = \langle ta, tb, tc \rangle$$

So that, the parametric equations of a line can be written as

$$x = x_1 + ta$$

$$y = y_1 + tb$$

$$z = z_1 + tc$$

or

$$\begin{bmatrix} x \\ y \\ z \end{bmatrix} = \begin{bmatrix} x_1 \\ y_1 \\ z_1 \end{bmatrix} + t \begin{bmatrix} a \\ b \\ c \end{bmatrix}$$

These equations can be described in terms of Cartesian equations when we eliminate the parameter of t from parametric equations. Therefore, we obtain

$$t = \frac{x - x_1}{a} = \frac{y - y_1}{b} = \frac{z - z_1}{c}, \quad a, b, c \neq 0.$$

Example 23

- a) Find a parametric equations of the line that passes through the point $P(1, 2, 3)$ and is parallel to the vector $\underline{v} = \langle 1, -1, 2 \rangle$.
- b) From the result of (a), state the parametric equations to the Cartesian equations.

Solutions

- a) Let $Q(x, y, z)$ be any point on l , then

$$\begin{aligned}\overrightarrow{PQ} &= t \cdot \underline{v}; \quad t \text{ is a scalar} \\ \langle x-1, y-2, z-3 \rangle &= t \cdot \langle 1, -1, 2 \rangle\end{aligned}$$

So that, the parametric equations of the line is

$$\begin{aligned}x &= 1 + t \\ y &= 2 - t \\ z &= 3 + 2t\end{aligned}$$

or

$$\begin{bmatrix} x \\ y \\ z \end{bmatrix} = \begin{bmatrix} 1 \\ 2 \\ 3 \end{bmatrix} + t \begin{bmatrix} 1 \\ -1 \\ 2 \end{bmatrix}$$

- b) From the result of (a) above, the cartesian equation is

$$t = \frac{x-1}{1} = \frac{2-y}{1} = \frac{z-3}{2}$$

vi) Distance from a Point to the Plane

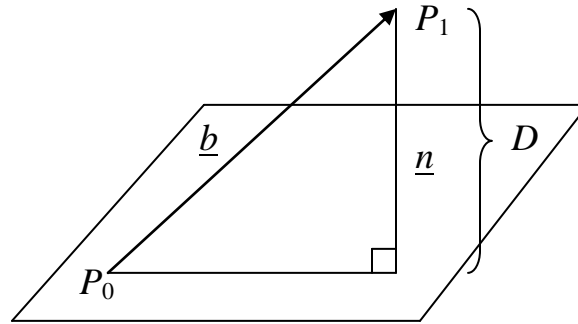

Let $P_0(x_0, y_0, z_0)$ be any point in the given plane and let \underline{b} be the vector corresponding to $\overrightarrow{P_0P_1}$, then

$$\underline{b} = \langle x - x_0, y - y_0, z - z_0 \rangle$$

From figure above, we can see that the distance D from P_1 to the plane is equal to the absolute value of the vector projection of \underline{b} onto the normal vector $\underline{n} = \langle a, b, c \rangle$. Thus

$$\begin{aligned} D &= |W_1| = \left| \left(\frac{\underline{n} \cdot \underline{b}}{|\underline{n}|^2} \right) \underline{n} \right| \\ &= \frac{|\underline{n} \cdot \underline{b}|}{|\underline{n}|} \\ &= \frac{|a(x - x_0) + b(y - y_0) + c(z - z_0)|}{\sqrt{a^2 + b^2 + c^2}} \\ &= \frac{|(ax + by + cz) - (ax_0 + by_0 + cz_0)|}{\sqrt{a^2 + b^2 + c^2}} \end{aligned}$$

Since $P_0(x_0, y_0, z_0)$ lies in the plane, its coordinates satisfy the equation of the plane and so we have $ax_0 + by_0 + cz_0 = -d$. Thus, the formula for D can be written as

$$D = \frac{|ax + by + cz + d|}{\sqrt{a^2 + b^2 + c^2}}$$

Example 24

Find the distance between the parallel planes $10x + 2y - 2z = 5$ and $5x + y - z = 1$.

Solution

If $S_1 = 10x + 2y - 2z = 5$, then $n_1 = \langle 10, 2, -2 \rangle$

If $S_2 = 5x + y - z = 1$, then $n_2 = \langle 5, 1, -1 \rangle$

Choose any point on S_1 plane and calculate its distance to the S_2 plane.

If we put $y = z = 0$ in the equation of the S_1 plane, then $x = \frac{1}{2}$. So

$(\frac{1}{2}, 0, 0)$ is a point in this plane. The distance between $(\frac{1}{2}, 0, 0)$ and the S_2 plane is

$$D = \frac{\left| 5\left(\frac{1}{2}\right) + 1(0) - 1(0) - 1 \right|}{\sqrt{5^2 + 1^2 + (-1)^2}} = \frac{\sqrt{3}}{6}$$